

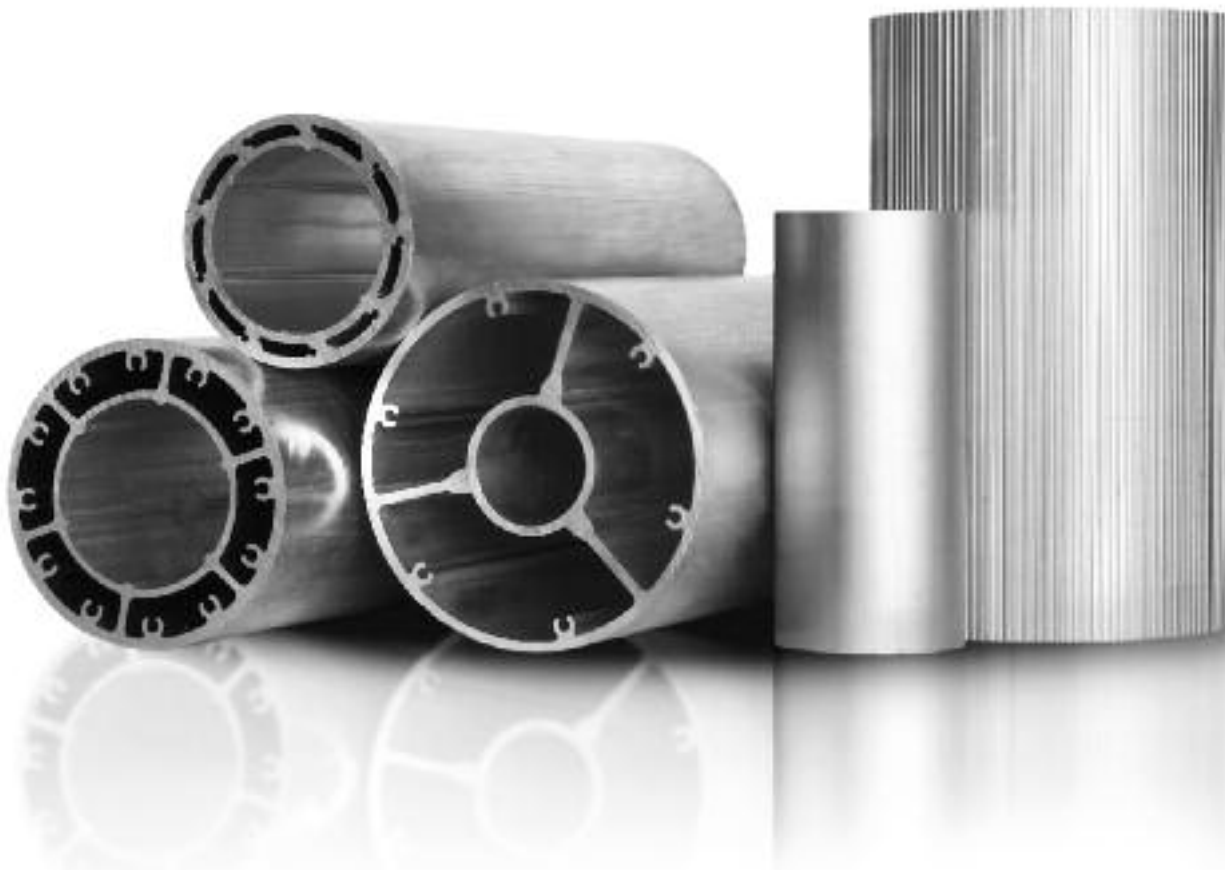

Patented Idler Technology



Componex is proud to present **WINertia**TM— the first aluminum tubing specifically designed, engineered and patented for idlers. **WINertia's**TM revolutionary design reduces idler manufacturing time up to 50%, and allows smoother, higher speed operation.

Visit us at www.componex.net for our full line of **WINertia's**TM products.

608.884.2201
608.884.2363 Fax
www.componex.net



COMPONEX
Innovation end to end.

10200 County Road F
Edgerton, WI 53534

Finally, Aluminum Tubing Specifically Designed and Engineered for Idlers

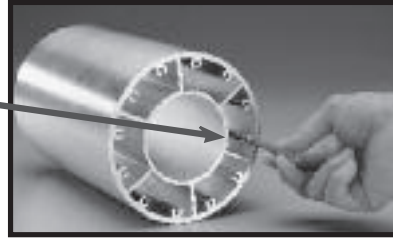

Dynamic 3D Balancing

Precise 3-D balancing is easily accomplished by driving weights to the center of the idler along built in balancing lugs. **WINertia™** idlers run faster with less whip than traditional idlers because of this unique balancing process.

No Endplugs

The inner wall of **WINertia™** tubing is extruded to match industry standards of 2.0472" or 3.1496". A simple clean up cut is all that is needed for bearing installation. Componex extending the bore to install a double bearing configuration to help to reduce deflection on wide web idlers.

$$\text{deflection} = \frac{5 (\text{load}) (\text{idler width})^3}{384 (\text{modulus of Elasticity}) (\text{area moment of inertia})}$$

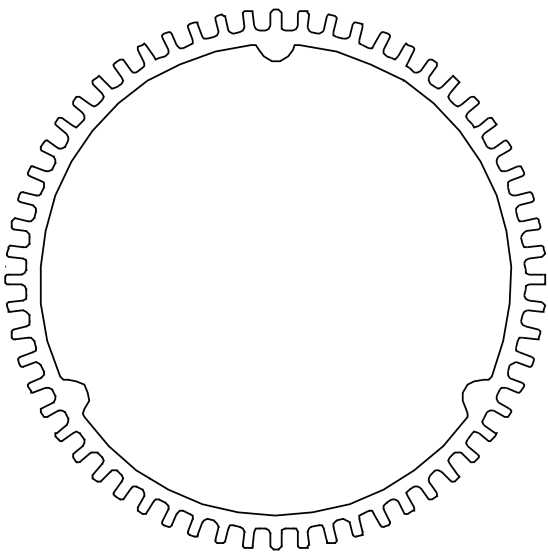

2.25 inch x 2 inch AV

Precision Specifications

- 2.310" Outside Diameter x .145" Outer Wall
- 2.020" Inside Diameter
- Alloy: 6005-T5 Aluminum
- Balancing Lug ID: N/A
- Bearing Bore: Machined to 2.0472" (Industry Standard)
- Bearing Sizes Available: 1.5", 2", 40 mm
- Modulus of Elasticity: 10,000,000 lb/in²
- Area: .642 in²
- Weight: .757 lbs/ft
- Area Moment of Inertia: .363 in⁴

Specifications are based upon raw material. The weight and inertia of finished idlers will be reduced by machining. For idler specifications, go to our product pages at www.componex.net

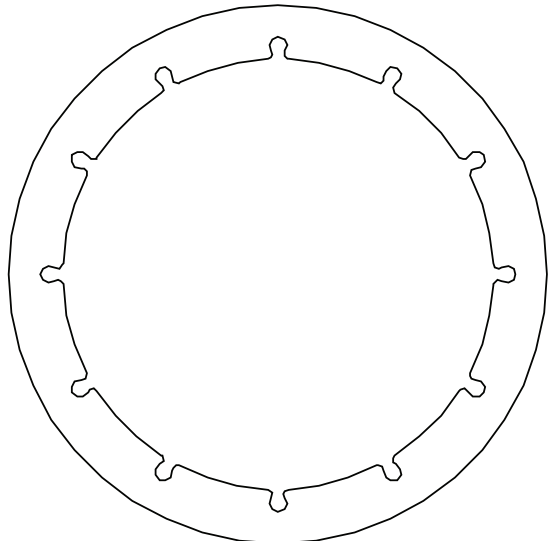

2.5 inch x 2 inch

Precision Specifications

- 2.500" Outside Diameter x .250" Outer Wall
- 2.0" Inside Diameter
- Alloy: 6005-T5 Aluminum
- Balancing Lug ID: 5/64" or .078"
- Bearing Bore: Machined to 2.0472" (Industry Standard)
- Bearing Sizes Available: .75", 1.0", 1.25" or 25mm
- Modulus of Elasticity: 10,000,000 lb/in²
- Area: 1.69 in²
- Weight: 1.99 lbs/ft
- Area Moment of Inertia: 1.09 in⁴

Specifications are based upon raw material. The weight and inertia of finished idlers will be reduced by machining. For idler specifications, go to our product pages at www.componex.net

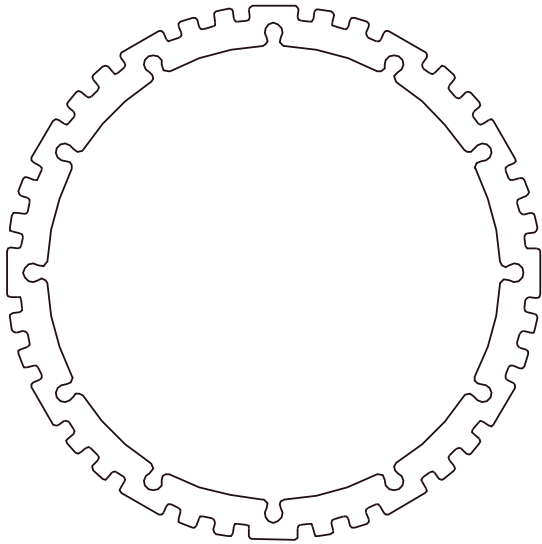

2.5 inch x 2 inch AV-36

Precision Specifications

- 2.360" Outside Diameter x .180" Outer Wall
- Alloy: 6005-T5 Aluminum
- Balancing Lug ID: 5/64" or .078"
- Bearing Bore: Machined to 2.0472" (Industry Standard)
- Bearing Sizes Available: .75", 1.0", 1.25" or 25mm
- Modulus of Elasticity: 10,000,000 lb/in²
- Area: .992 in²
- Weight: 1.17 lbs/ft
- Area Moment of Inertia: .587 in⁴

Specifications are based upon raw material. The weight and inertia of finished idlers will be reduced by machining. For idler specifications, go to our product pages at www.componex.net

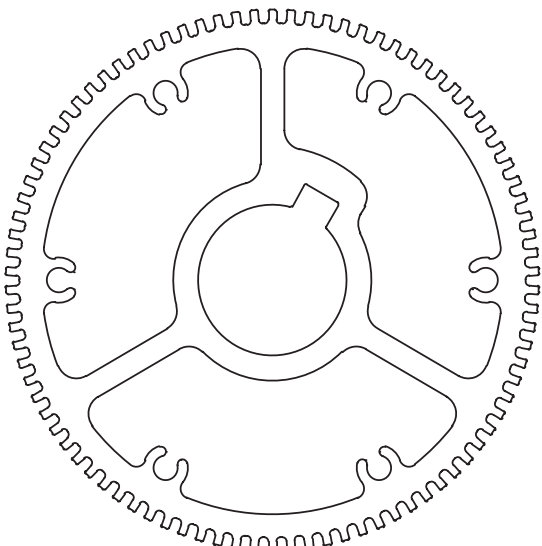

3 inch x 1 inch LS AV-90

Precision Specifications

- 3.4" Outside Diameter x .2325" Outer Wall
- .945" Inside Diameter x .1600" Inner Wall
- Alloy: 6005-T5 Aluminum
- Balancing Lug ID: 0.156"
- .25" Extruded Keyway
- Bearing Sizes Available: N/A
- Modulus of Elasticity: 10,000,000 lb/in²
- Area: 3.089 in²
- Weight: 3.64 lbs/ft
- Area Moment of Inertia: 2.81 in⁴

Specifications are based upon raw material. The weight and inertia of finished idlers will be reduced by machining. For idler specifications, go to our product pages at www.componex.net.

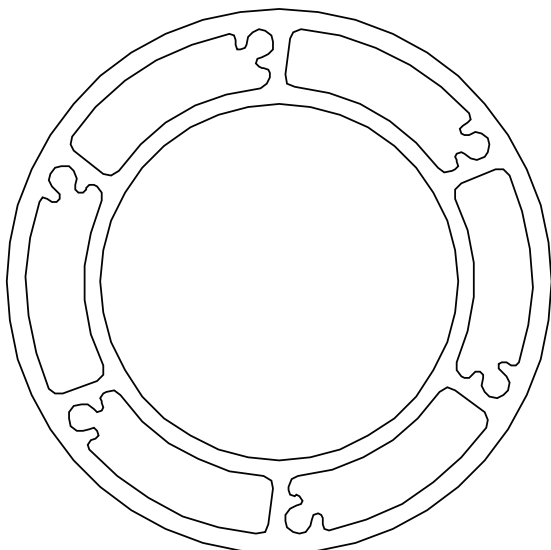

3 inch x 2 inch Lite

Precision Specifications

- 3.070" Outside Diameter x .107" Outer Wall
- 2.010" Inside Diameter x .095" Inner Wall
- Alloy: 6005-T5 Aluminum
- Balancing Lug ID: 5/32" or .156"
- Bearing Bore: Machined to 2.0472" (Industry Standard)
- Bearing Sizes Available: .75", 1.0", 1.25" or 25mm
- Modulus of Elasticity: 10,000,000 lb/in²
- Area: 1.90 in²
- Weight: 2.24 lbs/ft
- Area Moment of Inertia: 1.67 in⁴

Specifications are based upon raw material. The weight and inertia of finished idlers will be reduced by machining. For idler specifications, go to our product pages at www.componex.net

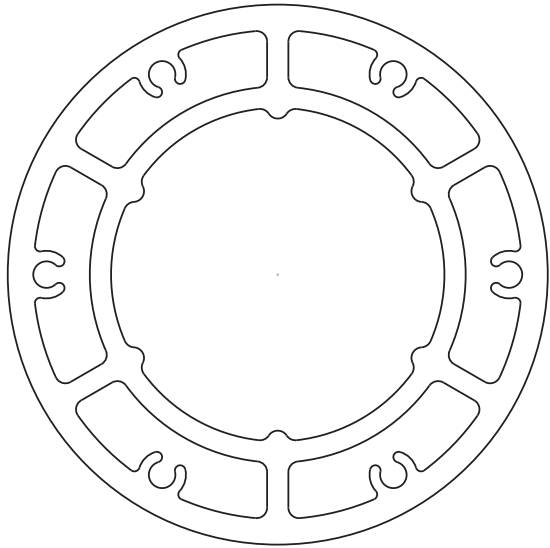

3.1 inch x 2 inch

Precision Specifications

- 3.175" Outside Diameter x .150" Outer Wall
- 1.960" Inside Diameter x .125" Inner Wall
- Alloy: 6005-T5 Aluminum
- Balancing Lug ID: 5/32" or .156"
- Bearing Bore: Machined to 2.0472" (Industry Standard)
- Bearing Sizes Available: .75", 1.0", 1.25" or 25mm
- Modulus of Elasticity: 10,000,000 lb/in²
- Area: 2.70 in²
- Weight: 3.19 lbs/ft
- Area Moment of Inertia: 2.46 in⁴

Specifications are based upon raw material. The weight and inertia of finished idlers will be reduced by machining. For idler specifications, go to our product pages at www.componex.net.

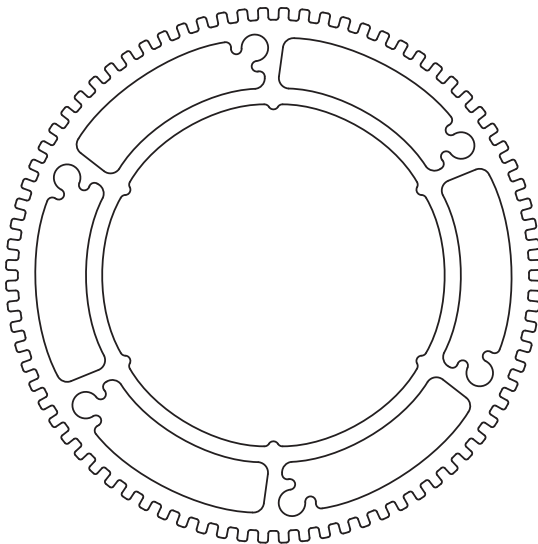

3.1 inch x 2 inch AV-80

Precision Specifications

- 3.140" Outside Diameter x .1725" Outer Wall
- 2.010" Inside Diameter x .190" Inner Wall
- Alloy: 6005-T5 Aluminum
- Balancing Lug ID: 5/32" or .156"
- Bearing Bore: Machined to 2.0472" (Industry Standard)
- Bearing Sizes Available: .75", 1.0", 1.25" or 25mm
- Modulus of Elasticity: 10,000,000 lb/in²
- Area: 2.13 in²
- Weight: 2.51 lbs/ft
- Area Moment of Inertia: 1.90 in⁴

Specifications are based upon raw material. The weight and inertia of finished idlers will be reduced by machining. For idler specifications, go to our product pages at www.componex.net.

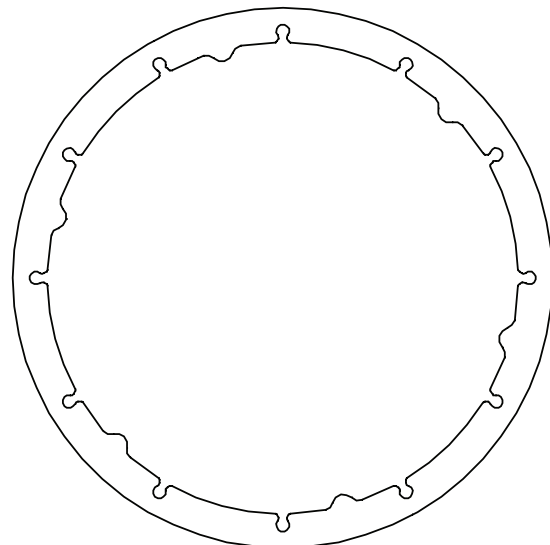

3.5 inch x 3 inch

Precision Specifications

- 3.550" Outside Diameter x .225" Outer Wall
- Alloy: 6005-T5 Aluminum
- Balancing Lug ID: 5/64" or .078"
- Bearing Bore: Machined to 3.1496" (Industry Standard)
- Bearing Sizes Available: 1.50", 2.0", or 40mm
- Modulus of Elasticity: 10,000,000 lb/in²
- Area: 2.31 in²
- Weight: 2.73 lbs/ft
- Area Moment of Inertia: 3.20 in⁴

Specifications are based upon raw material. The weight and inertia of finished idlers will be reduced by machining. For idler specifications, go to our product pages at www.componex.net.

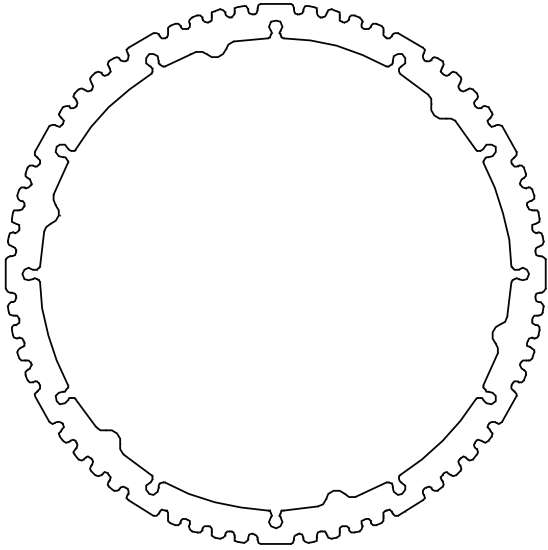

3.5 inch x 3 inch AV-60

Precision Specifications

- 3.550" Outside Diameter x .225" Outer Wall
- 3.100 Inside Diameter
- Alloy: 6005-T5 Aluminum
- Balancing Lug ID: 5/64" or .078"
- Bearing Bore: Machined to 3.1496" (Industry Standard)
- Bearing Sizes Available: 1.5", 2", or 40mm
- Modulus of Elasticity: 10,000,000 lb/in²
- Area: 2.03 in²
- Weight: 2.45 lbs/ft
- Area Moment of Inertia: 2.84 in⁴

Specifications are based upon raw material. The weight and inertia of finished idlers will be reduced by machining. For idler specifications, go to our product pages at www.componex.net.

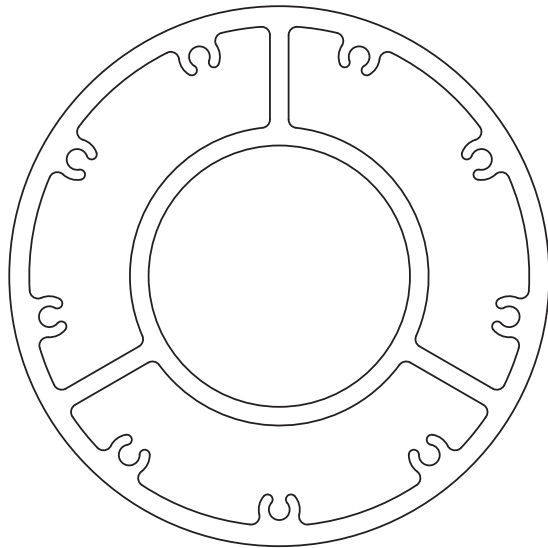

4 inch x 2 inch

Precision Specifications

- 4.050" Outside Diameter x .170" Outer Wall
- 1.960" Inside Diameter x .140" Inner Wall
- Alloy: 6005-T5 Aluminum
- Balancing Lug ID: 5/32" or .156"
- Bearing Bore: Machined to 2.0472" (Industry Standard)
- Bearing Sizes Available: .75", 1.0", 1.25" or 25mm
- Modulus of Elasticity: 10,000,000 lb/in²
- Area: 3.50 in²
- Weight: 4.14 lbs/ft
- Area Moment of Inertia: 5.05 in⁴

Specifications are based upon raw material. The weight and inertia of finished idlers will be reduced by machining. For idler specifications, go to our product pages at www.componex.net.

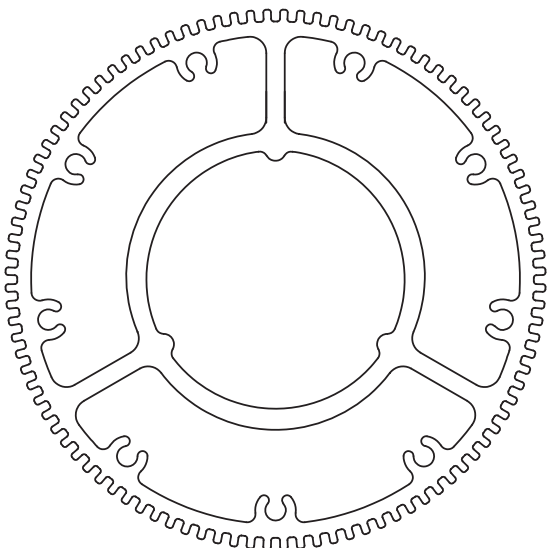

4 inch x 2 inch AV-100

Precision Specifications

- 4.1" Outside Diameter x .230" Outer Wall
- 1.960" Inside Diameter x .140" Inner Wall
- Alloy: 6005-T5 Aluminum
- Balancing Lug ID: 5/32" or .156"
- Bearing Bore: Machined to 2.0472" (Industry Standard)
- Bearing Sizes Available: .75", 1", 1.25", or 25mm
- Modulus of Elasticity: 10,000,000 lb/in²
- Area: 3.52 in²
- Weight: 4.16 lbs/ft
- Area Moment of Inertia: 4.88 in⁴

Specifications are based upon raw material. The weight and inertia of finished idlers will be reduced by machining. For idler specifications, go to our product pages at www.componex.net.

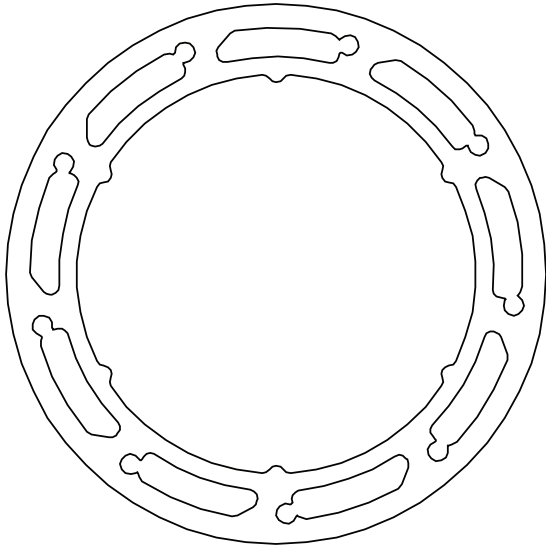

4 inch x 3 inch Precision Specifications

- 4.150" Outside Diameter x .175" Outer Wall
- 3.070" Inside Diameter x .140" Inner Wall
- Alloy: 6005-T5 Aluminum
- Balancing Lug ID: 5/32" or .156"
- Bearing Bore: Machined to 3.1496" (Industry Standard)
- Bearing Sizes Available: 1.5", 2", or 40mm
- Modulus of Elasticity: 10,000,000 lb/in²
- Area: 4.17 in²
- Weight: 4.92 lbs/ft
- Area Moment of Inertia: 7.05 in⁴

Specifications are based upon raw material. The weight and inertia of finished idlers will be reduced by machining. For idler specifications, go to our product pages at www.componex.net.

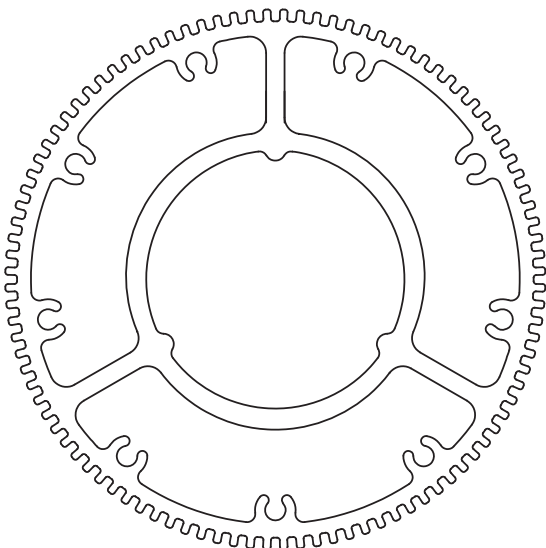

4 inch x 3 inch AV-90 Precision Specifications

- 4.150" Outside Diameter x .175" Outer Wall
- 3.070" Inside Diameter x .140" Inner Wall
- Alloy: 6005-T5 Aluminum
- Balancing Lug ID: 5/32" or .156"
- Bearing Bore: Machined to 3.1496" (Industry Standard)
- Bearing Sizes Available: 1.5", 2", or 40mm
- Modulus of Elasticity: 10,000,000 lb/in²
- Area: 3.83 in²
- Weight: 4.52 lbs/ft
- Area Moment of Inertia: 6.35 in⁴

Specifications are based upon raw material. The weight and inertia of finished idlers will be reduced by machining. For idler specifications, go to our product pages at www.componex.net.

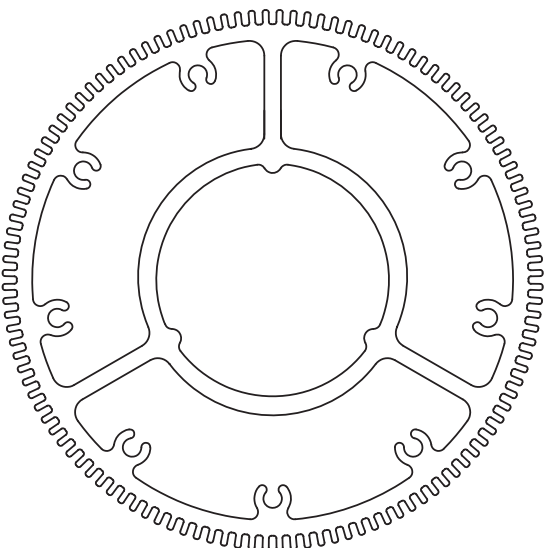

4.5 inch x 2 inch AV-120 Precision Specifications

- 4.550" Outside Diameter x .260" Outer Wall
- 1.960" Inside Diameter x .140" Inner Wall
- Alloy: 6005-T5 Aluminum
- Balancing Lug ID: 5/32" or .156"
- Bearing Bore: Machined to 2.0472" (Industry Standard)
- Bearing Sizes Available: .75", 1", 1-1/4", or 25mm
- Modulus of Elasticity: 10,000,000 lb/in²
- Area: 4.43 in²
- Weight: 5.22 lbs/ft
- Area Moment of Inertia: 7.62 in⁴

Specifications are based upon raw material. The weight and inertia of finished idlers will be reduced by machining. For idler specifications, go to our product pages at www.componex.net.

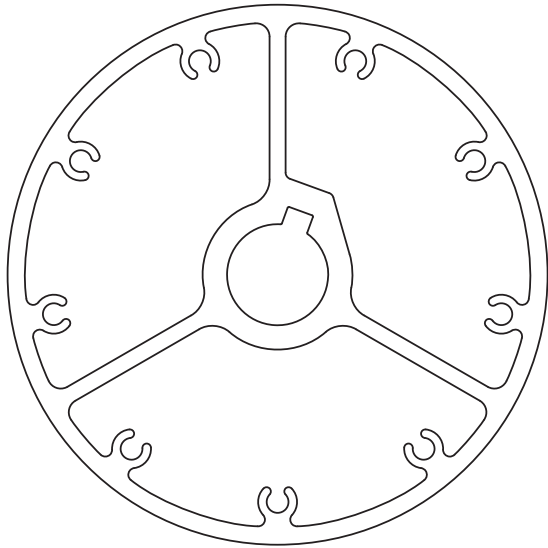

5 inch x 1 inch LS

Precision Specifications

- 5.050" Outside Diameter x .165" Outer Wall
- .945" Inside Diameter x .455" Inner Wall
- Alloy: 6005-T5 Aluminum
- Balancing Lug ID: 13/64" or .204"
- Bearing Sizes Available: N/A
- Modulus of Elasticity: 10,000,000 lb/in²
- Area: 4.93 in²
- Weight: 5.81 lbs/ft
- Area Moment of Inertia: 10.25 in⁴

Specifications are based upon raw material. The weight and inertia of finished idlers will be reduced by machining. For idler specifications, go to our product pages at www.componex.net.

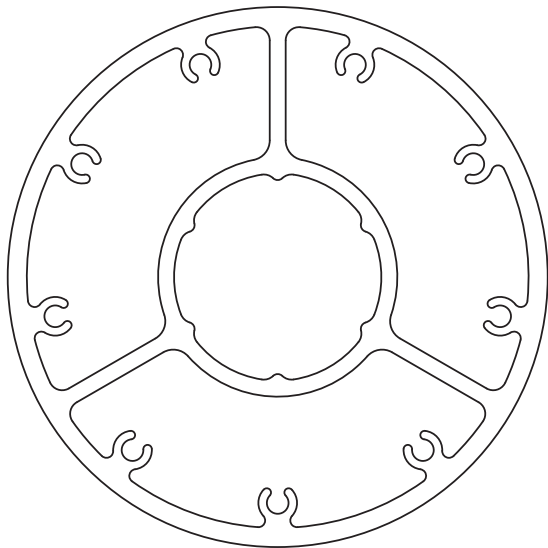

5 inch x 2 inch

Precision Specifications

- 5.080" Outside Diameter x .180" Outer Wall
- 1.950" Inside Diameter x .150" Inner Wall
- Alloy: 6005-T5 Aluminum
- Balancing Lug ID: 13/64" or .204"
- Bearing Bore: Machined to 2.0472" (Industry Standard)
- Bearing Sizes Available: .75", 1.0", 1.25" or 25mm
- Modulus of Elasticity: 10,000,000 lb/in²
- Area: 5.08 in²
- Weight: 5.99 lbs/ft
- Area Moment of Inertia: 11.46 in⁴

Specifications are based upon raw material. The weight and inertia of finished idlers will be reduced by machining. For idler specifications, go to our product pages at www.componex.net.

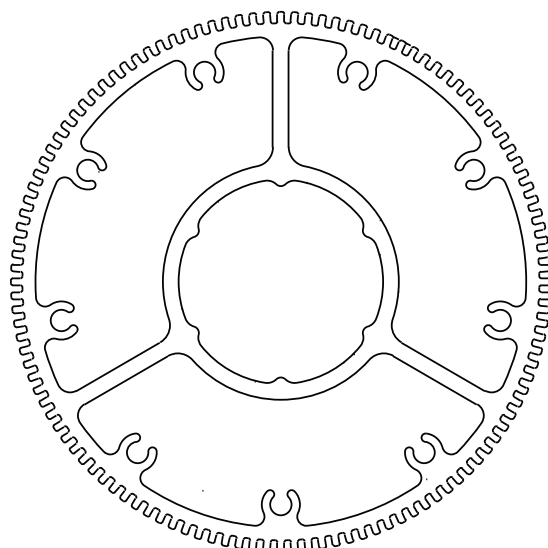

5 inch x 2 inch AV

Precision Specifications

- 5.150" Outside Diameter x .235" Outer Wall
- 1.950" Inside Diameter x .150" Inner Wall
- Alloy: 6005-T5 Aluminum
- Balancing Lug ID: 13/64" or .204"
- Bearing Bore: Machined to 2.0472" (Industry Standard)
- Bearing Sizes Available: .75", 1.0", 1.25", 25mm
- Modulus of Elasticity: 10,000,000 lb/in²
- Area: 5.12 in²
- Weight: 6.03 lbs/ft
- Area Moment of Inertia: 11.46 in⁴

Specifications are based upon raw material. The weight and inertia of finished idlers will be reduced by machining. For idler specifications, go to our product pages at www.componex.net.

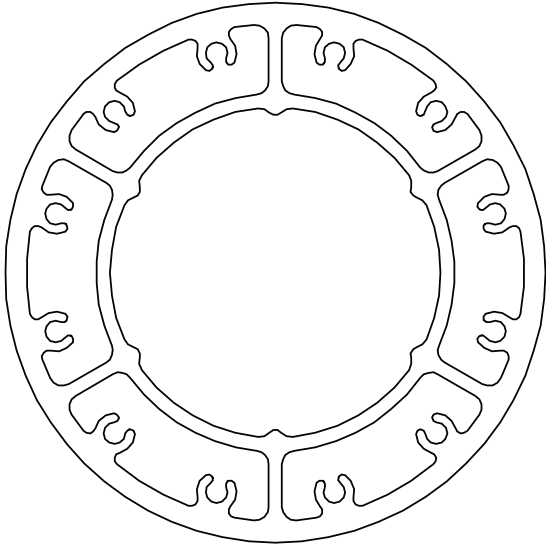

5 inch x 3 inch

Precision Specifications

- 5.050" Outside Diameter x .200" Outer Wall
- 3.070" Inside Diameter x .140" Inner Wall
- Alloy: 6005-T5 Aluminum
- Balancing Lug ID: 13/64" or .204"
- Bearing Bore: Machined to 3.1496" (Industry Standard)
- Bearing Sizes Available: 1.5", 2", or 40mm
- Modulus of Elasticity: 10,000,000 lb/in²
- Area: 5.90 in²
- Weight: 6.96 lbs/ft
- Area Moment of Inertia: 14.08 in⁴

Specifications are based upon raw material. The weight and inertia of finished idlers will be reduced by machining. For idler specifications, go to our product pages at www.componex.net.

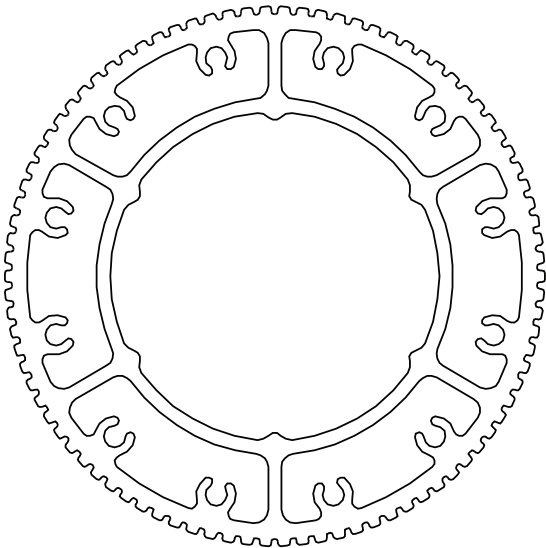

5 inch x 3 inch AV-90

Precision Specifications

- 5.070" Outside Diameter x .210" Outer Wall
- 3.090" Inside Diameter x .130" Inner Wall
- Alloy: 6005-T5 Aluminum
- Balancing Lug ID: 13/64" or .204"
- Bearing Bore: Machined to 3.1496" (Industry Standard)
- Bearing Sizes Available: 1.5", 2", or 40mm
- Modulus of Elasticity: 10,000,000 lb/in²
- Area: 5.66 in²
- Weight: 6.68 lbs/ft
- Area Moment of Inertia: 13.34 in⁴

Specifications are based upon raw material. The weight and inertia of finished idlers will be reduced by machining. For idler specifications, go to our product pages at www.componex.net.



6 inch x 2 inch

Precision Specifications

- 5.95" Outside Diameter x .180" Outer Wall
- 1.950" Inside Diameter x .1085" Inner Wall
- Alloy: 6005-T5 Aluminum
- Balancing Lug ID: 13/64" or .204"
- Bearing Bore: Machined to 2.0472" (Industry Standard)
- Bearing Sizes Available: .75", 1.0", 1.25" or 25mm
- Modulus of Elasticity: 10,000,000 lb/in²
- Area: 5.86 in²
- Weight: 6.91 lbs/ft
- Area Moment of Inertia: 18.10 in⁴

Specifications are based upon raw material. The weight and inertia of finished idlers will be reduced by machining. For idler specifications, go to our product pages at www.componex.net.

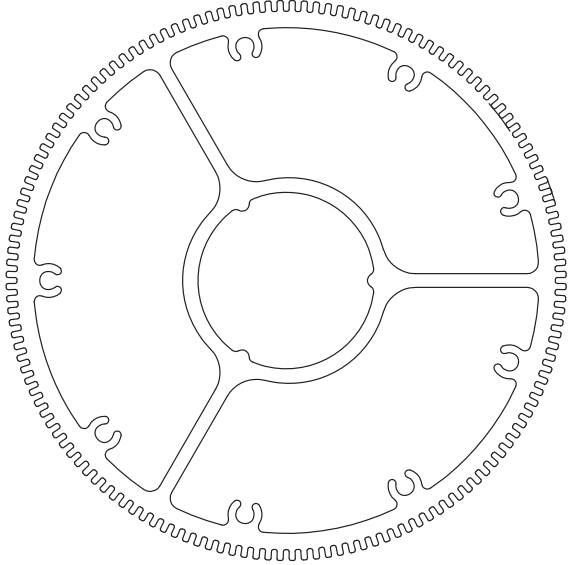

6 inch x 2 inch AV

Precision Specifications

- 1.960" Outside Diameter x .230" Outer Wall
- 1.960" Inside Diameter x .140" Inner Wall
- Alloy: 6005-T5 Aluminum
- Balancing Lug ID: 13/64" or .203"
- Bearing Bore: Machined to 2.0472" (Industry Standard)
- Bearing Sizes Available: .75", 1.0", 1.25" or 25mm
- Modulus of Elasticity: 10,000,000 lb/in²
- Area: 7.03 in²
- Weight: 8.29 lbs/ft
- Area Moment of Inertia: 23.48 in⁴

Specifications are based upon raw material. The weight and inertia of finished idlers will be reduced by machining. For idler specifications, go to our product pages at www.componex.net.

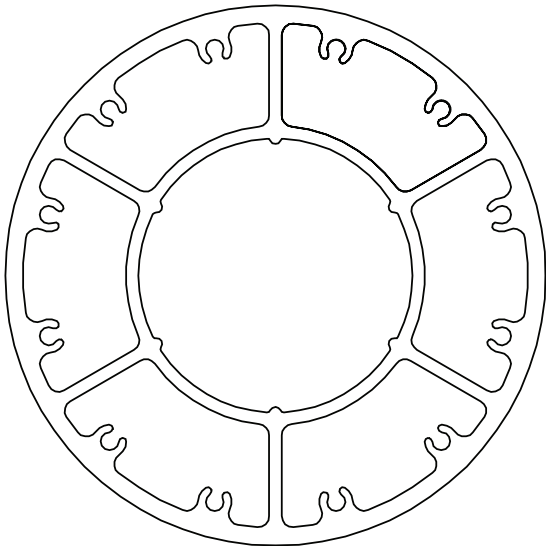

6 inch x 3 inch

Precision Specifications

- 6.050" Outside Diameter x .200" Outer Wall
- 3.070" Inside Diameter x .140" Inner Wall
- Alloy: 6005-T5 Aluminum
- Balancing Lug ID: 13/64" or .204"
- Bearing Bore: Machined to 3.1496" (Industry Standard)
- Bearing Sizes Available: 1.5", 2", or 40mm
- Modulus of Elasticity: 10,000,000 lb/in²
- Area: 7.24 in²
- Weight: 8.54 lbs/ft
- Area Moment of Inertia: 24.22 in⁴

Specifications are based upon raw material. The weight and inertia of finished idlers will be reduced by machining. For idler specifications, go to our product pages at www.componex.net.

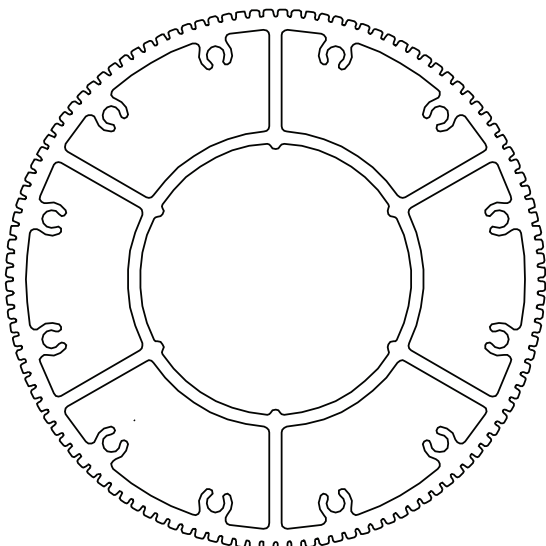

6 inch x 3 inch AV-120

Precision Specifications

- 6.100" Outside Diameter x .225" Outer Wall
- 3.070" Inside Diameter x .140" Inner Wall
- Alloy: 6005-T5 Aluminum
- Balancing Lug ID: 13/64" or .204"
- Bearing Bore: Machined to 3.1496" (Industry Standard)
- Bearing Sizes Available: 1.5", 2", or 40mm
- Modulus of Elasticity: 10,000,000 lb/in²
- Area: 7.00 in²
- Weight: 8.32 lbs/ft
- Area Moment of Inertia: 23.60 in⁴

Specifications are based upon raw material. The weight and inertia of finished idlers will be reduced by machining. For idler specifications, go to our product pages at www.componex.net.

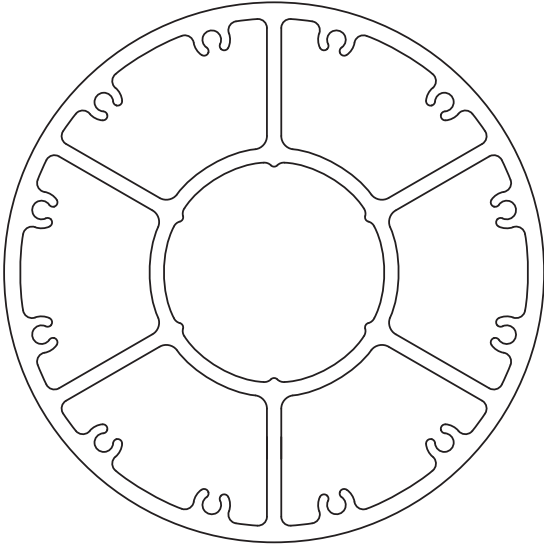

7.5 inch x 3 inch

Precision Specifications

- 7.525" Outside Diameter x .225" Outer Wall
- 3.070" Inside Diameter x .200" Inner Wall
- Alloy: 6005-T5 Aluminum
- Balancing Lug ID: .260"
- Bearing Bore: Machined to 3.1496" (Industry Standard)
- Bearing Sizes Available: 1.5", 2", or 40mm
- Modulus of Elasticity: 10,000,000 lb/in²
- Area: 10.97 in²
- Weight: 12.95 lbs/ft
- Area Moment of Inertia: 53.65 in⁴

Specifications are based upon raw material. The weight and inertia of finished idlers will be reduced by machining. For idler specifications, go to our product pages at www.componex.net.

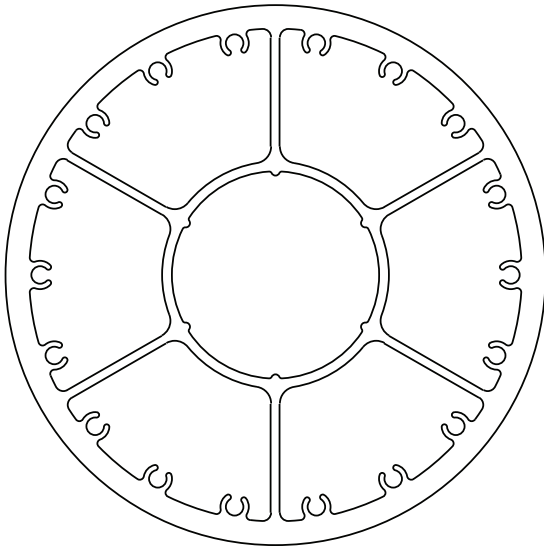

8 inch x 3 inch

Precision Specifications

- 8.00" Outside Diameter x .350" Outer Wall
- 3.070" Inside Diameter x .145" Inner Wall
- Alloy: 6005-T5 Aluminum
- Balancing Lug ID: 1/4" or .260"
- Bearing Bore: Machined to 3.1496" (Industry Standard)
- Bearing Sizes Available: 1.5", 2", or 40mm
- Modulus of Elasticity: 10,000,000 lb/in²
- Area: 12.82 in²
- Weight: 15.12lbs/ft
- Area Moment of Inertia: 77.20 in⁴

Specifications are based upon raw material. The weight and inertia of finished idlers will be reduced by machining. For idler specifications, go to our product pages at www.componex.net

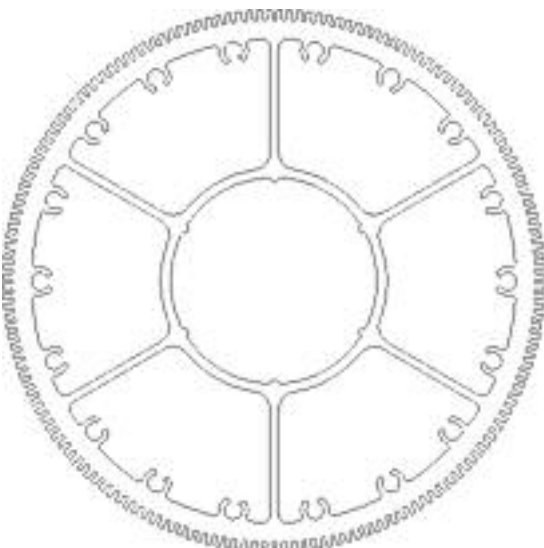

8 inch x 3 inch AV-168

Precision Specifications

- 8.100" Outside Diameter x .432" Outer Wall
- 3.070" Inside Diameter x .145" Inner Wall
- Alloy: 6005-T5 Aluminum
- Balancing Lug ID: 13/50" or .260"
- Bearing Bore: Machined to 3.1496" (Industry Standard)
- Bearing Sizes Available: 1.5", 2", or 40mm
- Modulus of Elasticity: 10,000,000 lb/in²
- Area: 12.87 in²
- Weight: 15.18 lbs/ft
- Area Moment of Inertia: 77.14 in⁴

Specifications are based upon raw material. The weight and inertia of finished idlers will be reduced by machining. For idler specifications, go to our product pages at www.componex.net

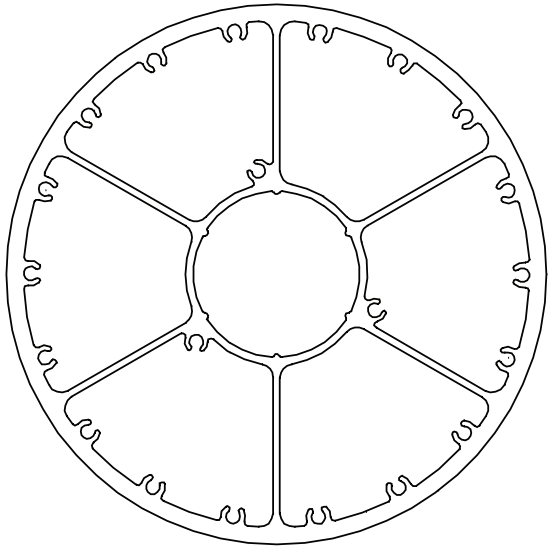

10 inch x 3 inch

Precision Specifications

- 9.970" Outside Diameter x .310" Outer Wall
- 3.070" Inside Diameter x .145" Inner Wall
- Alloy: 6005-T5 Aluminum
- Balancing Lug ID: 1/4" or .260"
- Bearing Bore: Machined to 3.1496" (Industry Standard)
- Bearing Sizes Available: 1.5", 2", or 40mm
- Modulus of Elasticity: 10,000,000 lb/in²
- Area: 15.10 in²
- Weight: 17.81 lbs/ft
- Area Moment of Inertia: 139.86 in⁴

Specifications are based upon raw material. The weight and inertia of finished idlers will be reduced by machining. For idler specifications, go to our product pages at www.componex.net

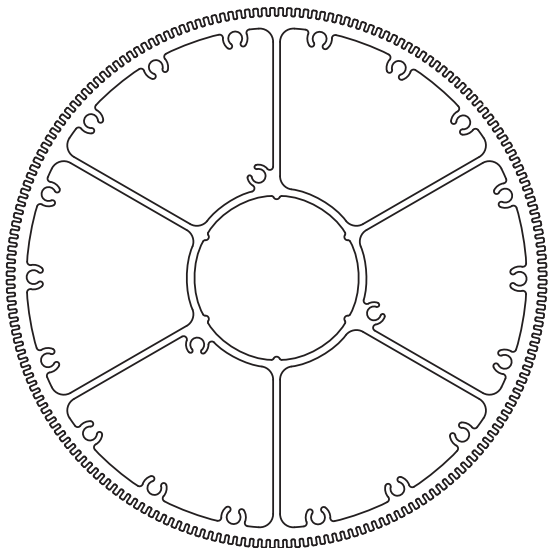

10 inch x 3 inch AV-200

Precision Specifications

- 10.100" Outside Diameter x .187" Outer Wall
- 3.070" Inside Diameter x .145" Inner Wall
- Alloy: 6005-T5 Aluminum
- Balancing Lug ID: 13/50" or .260"
- Bearing Bore: Machined to 3.1496" (Industry Standard)
- Bearing Sizes Available: 1.5", 2", or 40mm
- Modulus of Elasticity: 10,000,000 lb/in²
- Area: 15.07 in²
- Weight: 17.78 lbs/ft
- Area Moment of Inertia: 139.90 in⁴

Specifications are based upon raw material. The weight and inertia of finished idlers will be reduced by machining. For idler specifications, go to our product pages at www.componex.net

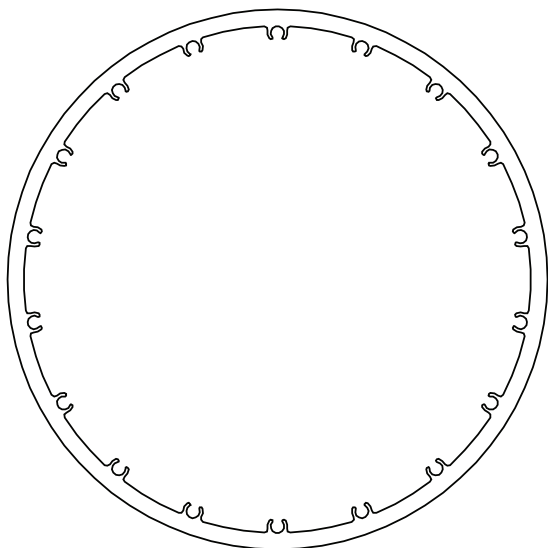

10 inch Outer Shell

Precision Specifications

- Uses cast aluminum headers
- 10.00" Outside Diameter x .188" Outer Wall
- Alloy: 6005-T5 Aluminum
- Balancing Lug ID: .255"
- Bearing Bore: Machined to 3.1496" (Industry Standard)
- Bearing Sizes Available: 1.5", 2", or 40mm
- Modulus of Elasticity: 10,000,000 lb/in²
- Area: 6.495 in²
- Weight: 7.66 lbs/ft
- Area Moment of Inertia: 77.52 in⁴

Specifications are based upon raw material. The weight and inertia of finished idlers will be reduced by machining. For idler specifications, go to our product pages at www.componex.net



The demand for WINertia products is expanding and so is our range of sizes. This catalog shows the full range of sizes to date of publication. You can also check our website (componex.net) for more detailed product information, up to the minute size additions and to use our free deflection calculator.

In addition to our WINertia™ tubing, Componex sets the standard in precision aluminum roll manufacturing with the patented WINertia™ product line. The lightweight design, unique 3D balancing process, and streamlined manufacturing process delivers a premium product at a competitive cost.

Standard Winertia™



Standard WINertia™ lightweight aluminum dead shaft idlers give you up to 30% less rotational inertia than standard aluminum idlers. This is our most versatile idler and is known for its durability, high performance and easy installation.

WINertia™ dead shaft idlers are the most economical solution when a free spinning roll is needed.

Winertia^{AV}™



The innovative WINertia AV™ eliminates trapped air, along with scratching, slipping, bunching and side movement in a more effective and less costly roll solution than the traditional spiral groove. And the WINertia AV™ gets the air out 7.5 times faster and has 15 times the air parking capacity.

Winertia^{LS}

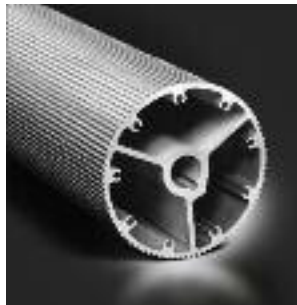

WINertia™ LS (Live Shaft) technology incorporates some of the same advantages that are provided by WINertia dead shaft idler technology. WINertia LS offers a simple manufacturing solution featuring an extruded keyway which allows a keyed shaft to press fit into the bore. This eliminates

the hassle of customization and the high costs associated with it.

Winertia[™] Bearings



WINertia Bearings are incredibly free spinning bearings that have literally set a new industry standard. Utilizing a hi-tech synthetic lubricant, Componex manufactures WINertia™ idlers with one of the lowest drag bearings in the industry. It increases bearing life with the added benefit of reduced noise.

Try our Deflection Calculator to determine the best shaft and roller combination for your idler applications. Start reducing deflection today at www.componex.net

10200 County Road F
Edgerton, WI 53534

608.884.2201
608.884.2363 Fax

www.componex.net



COMPONEX
Innovation end to end.